

Редуктор, Мотор-редуктор CH0100 MOTOVARIO

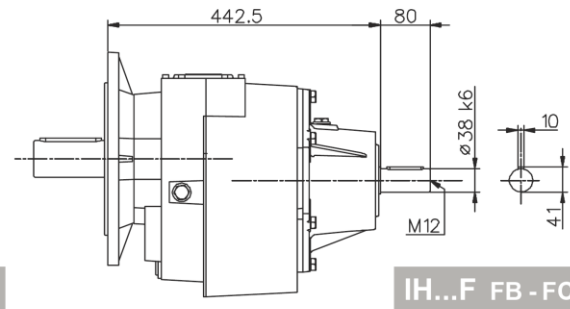
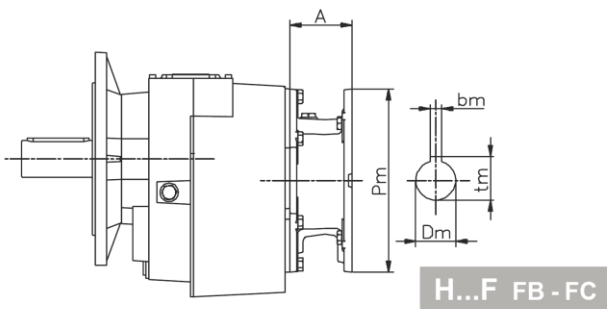
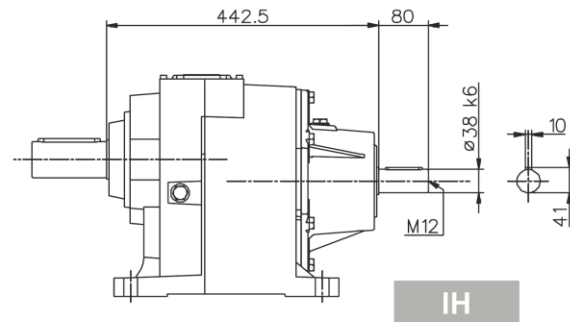
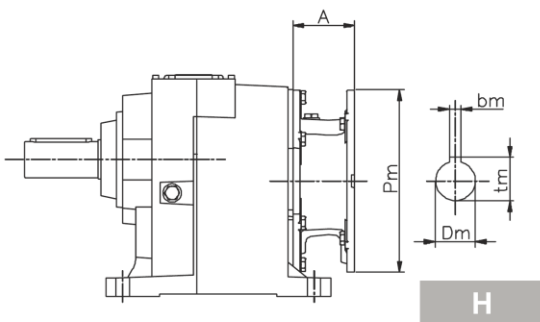
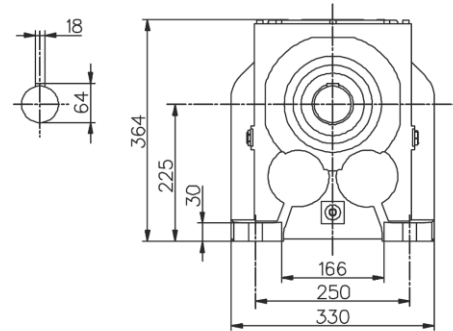
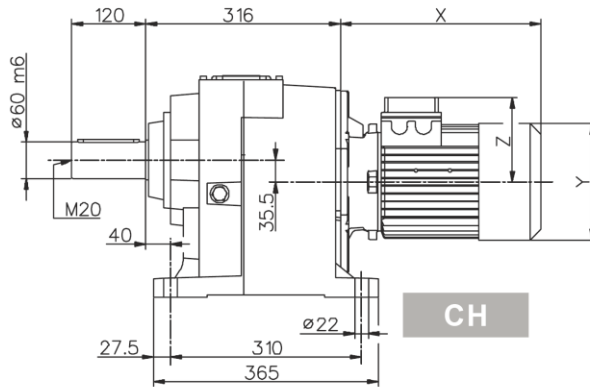

100	IH	PAM		Motore normale / Standard motor / Normaler Motor / Moteur normal / Motor normal				Motore autofrenante / Brake motor / Bremsmotor Moteur frein / Motor-freno			
		~Kg	A	~Kg	X	Y	Z	~Kg	X	Y	Z
90s	94,7	61	84,8	267	173	130	93,8	343	173	130	99,4
90l		61	84,8	292	173	130	94,8	368	173	130	100,4
100		76	87,1	326	191	139	100,8	407	191	139	106,4
112		76	87,1	347	211	154	110,8	443	211	154	120,6
132s		101	89,9	386	249	194	125,8	485	249	194	136,2
132m		101	89,9	434	249	194	134,8	537	249	194	149,6
160s		148	95,9	540	310	244	-	-	-	-	-
160l		148	95,9	584	310	244	-	-	-	-	-
180	148	95,9	641	349	260	-	-	-	-	-	