

Чертежи и монтажные позиции червячных мотор-редукторов серии XC

XA

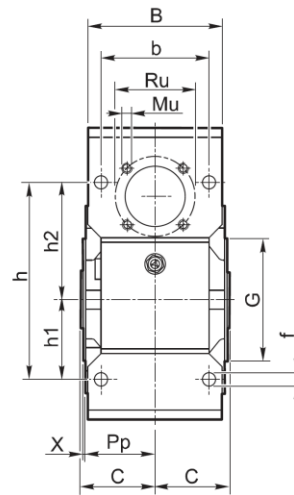

XF

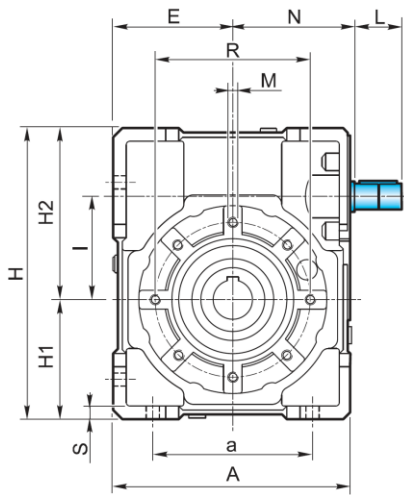
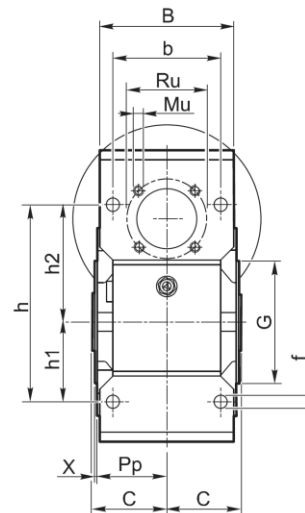
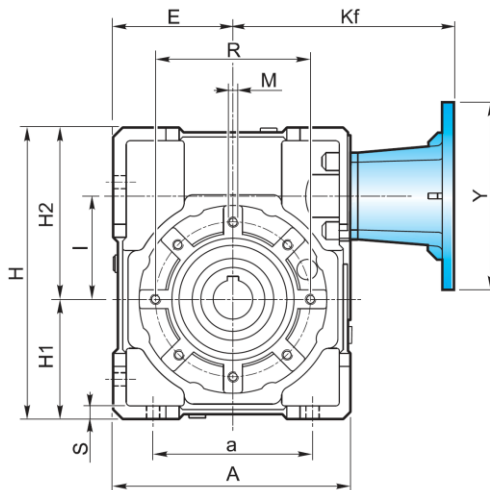

XC

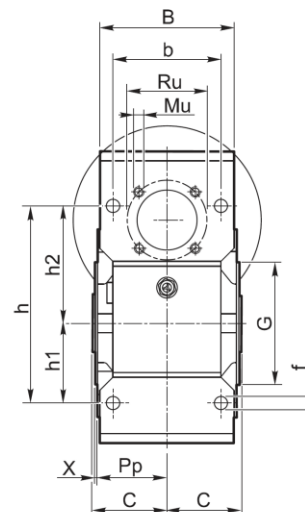
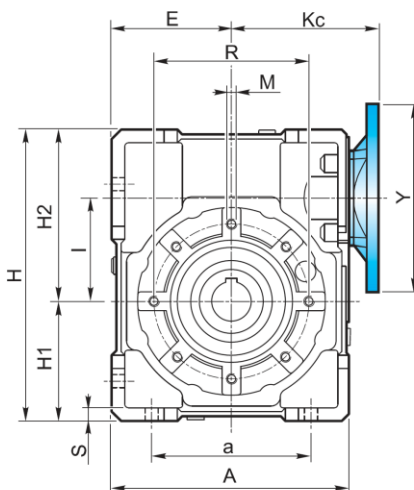

Чертежи и монтажные позиции червячных мотор-редукторов серии ХС

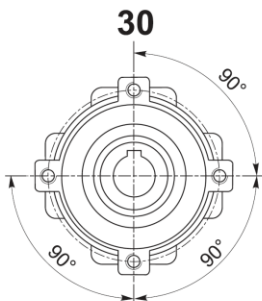

4 Fori / Holes / Bohrungen

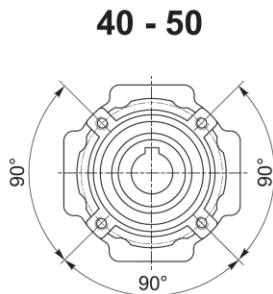

4 Fori / Holes / Bohrungen

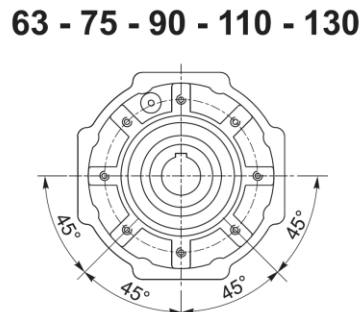

8 Fori / Holes / Bohrungen

Albero uscita cavo
Output hollow shaft
Abtriebshohlwelle

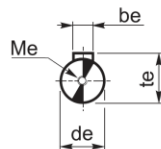
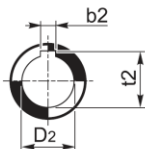

Albero entrata
Input shaft
Antriebswelle

X	A	a	B	b	b _e	b ₂	C	d _e j6	D ₂ H7	E	f	G h8	H	H ₁	H ₂	h	h ₁	h ₂		
30	80	54	56	44	3	5	—	31.5	9	14	—	40	6.5	55	97	40	57	71	27	44
40	105	70	71	60	4	6	6	39	11	18	19	50	6.5	60	125	50	75	90	35	55
50	125	80	85	70	5	8	8	46	14	25	24	60	8.5	70	150	60	90	104	40	64
63	147	100	103	85	6	8	—	56	19	25	—	72	9	80	182	72	110	130	50	80
75	176	120	112	90	8	8	8	60	24	28	30	86	11	95	219.5	86	133.5	153	60	93
90	203	140	130	100	8	10	—	70	24	35	—	103	13	110	248.5	103	145.5	172	70	102
110	252.5	170	143	115	8	12	—	77.5	28	42	—	127.5	14	130	310.5	127.5	183	210	85	125
130	292.5	200	155	120	10	14	14	85	38	45	48	147.5	15	180	355	147.5	207.5	240	100	140

X	I	K _c	K _f	L	M	M _e	M _u	N	P _p	R	R _u	S	t _e	t ₂	X	
30	31.5	57	vedi pag. see page siehe S. 32	15	M6x8	M4x10	M5x7.5	44.5	29	65	35.4	5.5	10.2	16.3	—	1.5
40	40	75		20	M6X10	M4X12	M5X10	57.5	36.5	75	42.4	6	12.5	20.8	21.8	1.5
50	50	82		25	M8x10	M5x13	M6x10	67.5	43.5	85	53.7	7	16	28.3	27.3	1.5
63	63	95		30	M8x14	M8x20	M6x12	77.5	53	95	60.8	8	21.5	28.3	—	2
75	75	112		40	M8x14	M8x20	M8x12	95	57	115	70.7	10	27	31.3	33.3	2
90	90	122		40	M10x18	M8x20	M8x14	105	67	130	70.7	12	27	38.3	—	2
110	110	153		50	M10x18	M8x20	M10x18	130	74	165	85.0	14	31	45.3	—	2.5
130	130	173		70	M12x20	M10x25	M10x16	152	81	215	104	15	41	48.8	51.8	3

Чертежи и монтажные позиции червячных мотор-редукторов серии XC

Выходной фланец

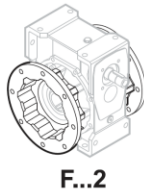
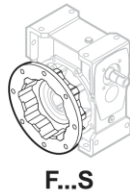
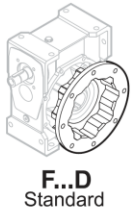
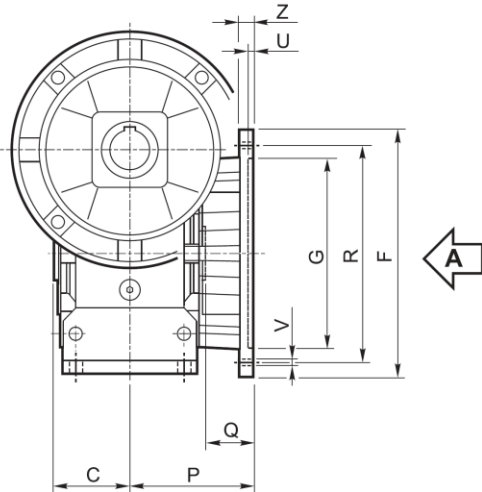

Vista da A / View from A / Ansicht von A

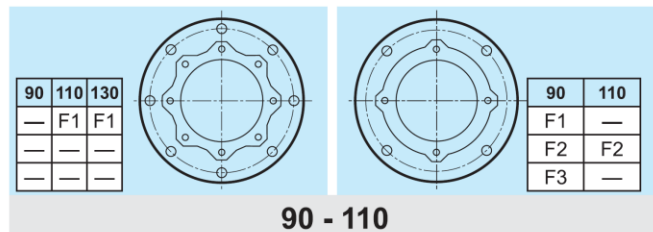
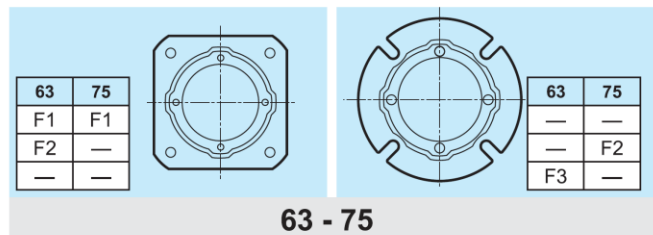
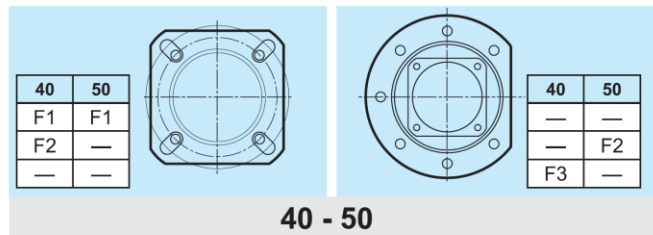
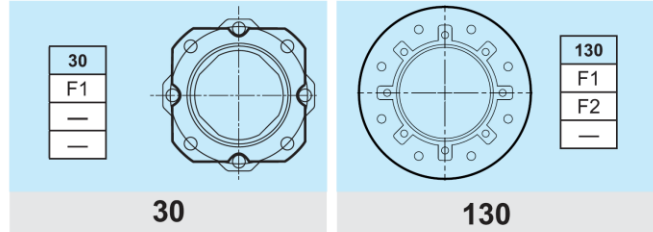

Тип Type Typ	C	F		G H8	P	Q	R	U	V			Z		
											Ø			
30	F1	31.5		66	50	54.5	23	68	4	n° 4		6.5	6	
	F2													
	F3													
40	F1	39		85	60	67	28	75-90	4	n° 4		9	8	
	F2			85	60	97	58	75-90	4	n° 4		9	8	
	F3			140	95	80	41	115	5	n° 7		9	10	
50	F1	46		94	70	90	44	85-100	5	n° 4		11	10	
	F2			160	110	89	43	130	5	n° 7		11	11	
	F3													
63	F1	56		142	115	82	26	150	5	n° 4		11	11	
	F2			142	115	112	56	150	5	n° 4		11	11	
	F3			160	110	80.5	24.5	130	5	n° 4		11	12	
75	F1	60		160	130	111	51	165	5	n° 4		13	12	
	F2			160	110	90	30	130	6	n° 4		11	13	
	F3													
90	F1	70		200	152	111	41	175	5	n° 4		13	12	
	F2			200	152	151	81	175	5	n° 4		13	13	
	F3			200	130	110	40	165	6	n° 4		11	11	
110	F1	77.5		260	170	131	53.5	230	6	n° 4		n° 8	13	15
	F2			250	180	150	72.5	215	5	n° 4		15	16	
	F3													
130	F1	85		320	180	140	55	255	7		n° 8 *	16	16	
	F2			300	230			265						
	F3													

Входной фланец

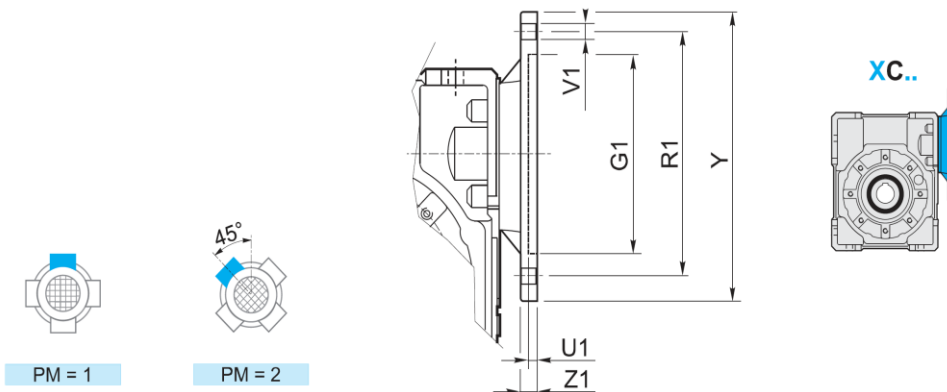

XC	IEC	G _{H7}	PM		R ₁	U ₁	V ₁			Y	Z ₁	Diametro fori PAM / Holes diameter IEC / IEC Durchmesser											
			1	2			Ø						7.5	10	15	20	25	30	40	50	65	80	100
30	56 B5	80	•	•	100	4	7	8			8	9	9	9	9	9	9	9	9	9	9	9	9
	56 B14	50	•	•	65	3.5	6	8			80	8	9	9	9	9	9	9	9	9	9	9	9
	63 B5	95	•	•	115	4	9	8			140	8	11	11	11	11	11	11	11	11	/	/	/
	63 B14	60	•	•	75	4	6	8			90	8	11	11	11	11	11	11	11	11	/	/	/
40	56 B5	80	•	•	100	4	7	8			120	9	/	/	/	/	/	/	/	9	9	9	9
	56 B14	50	•	•	65	3.5	6		4	80	8	/	/	/	/	/	/	/	9	9	9	9	
	63 B5	95	•	•	115	4	9	8			140	9	11	11	11	11	11	11	11	11	11	11	11
	63 B14	60	•	•	75	3.5	6		4	90	8	11	11	11	11	11	11	11	11	11	11	11	11
	71 B5	110	•	•	130	4.5	9	8			160	10	14	14	14	14	14	14	14	/	/	/	/
	71 B14	70	•	•	85	3.5	7	8			105	8	14	14	14	14	14	14	14	/	/	/	/
	80 B5	130	•	•	165	4.5	11	8			200	10	19	19	19	19	19	19	19	/	/	/	/
50	63 B5	95	•	•	115	4	9	8			140	9	/	/	/	/	/	/	11	11	11	11	11
	63 B14	60	•	•	75	3.5	6		4	90	8	/	/	/	/	/	/	11	11	11	11	11	11
	71 B5	110	•	•	130	4.5	9	8			160	10	14	14	14	14	14	14	14	14	14	14	14
	71 B14	70	•	•	85	3.5	7	8		4	105	8	14	14	14	14	14	14	14	14	14	14	14
	80 B5	130	•	•	165	4.5	11	8			200	10	19	19	19	19	19	19	19	/	/	/	/
	80 B14	80	•	•	100	4	7	8		4	120	10	19	19	19	19	19	19	19	/	/	/	/
	90 B5	130	•	•	165	4.5	11	8			200	10	24	24	24	24	24	24	/	/	/	/	/
63	90 B14	95	•	•	115	4	8.5	8			140	10	24	24	24	24	24	24	/	/	/	/	/
	80 B5	130	•	•	165	4.5	11	8			200	10	/	/	/	/	/	/	19	19	19	19	19
	80 B14	80	•	•	100	4	7	8		4	120	11	/	/	/	/	/	/	19	19	19	19	19
	90 B5	130	•	•	165	4.5	11	8			200	10	24	24	24	24	24	24	24	24	24	24	24
	90 B14	95	•	•	115	4	9	8		4	140	11	24	24	24	24	24	24	24	24	24	24	24
	100/112 B5	180	•	•	215	5	14	8			250	13	28	28	28	28	28	28	/	/	/	/	/
	100/112 B14	110	•	•	130	4.5	9	8			160	11	28	28	28	28	28	28	/	/	/	/	/
75	80 B5	130	•	•	165	4.5	11	8			200	10	/	/	/	/	/	/	19	19	19	19	19
	80 B14	80	•	•	100	4	7	8		4	120	11	/	/	/	/	/	/	19	19	19	19	19
	90 B5	130	•	•	165	4.5	11	8			200	10	24	24	24	24	24	24	24	24	24	24	24
	90 B14	95	•	•	115	4	9	8		4	140	11	24	24	24	24	24	24	24	24	24	24	24
	100/112 B5	180	•	•	215	5	14	8			250	13	28	28	28	28	28	28	/	/	/	/	/
	100/112 B14	110	•	•	130	4.5	9	8			160	11	28	28	28	28	28	28	/	/	/	/	/
	90 B5	130	•	•	165	4.5	11	8			200	10	/	/	/	/	/	/	19	19	19	19	19
90	80 B14	80	•	•	100	4	7	8		4	120	11	/	/	/	/	/	/	19	19	19	19	19
	90 B5	130	•	•	165	4.5	11	8			200	10	24	24	24	24	24	24	24	24	24	24	24
	90 B14	95	•	•	115	4	9	8		4	140	11	24	24	24	24	24	24	24	24	24	24	24
	100/112 B5	180	•	•	215	5	14	8			250	13	28	28	28	28	28	28	/	/	/	/	/
	100/112 B14	110	•	•	130	4.5	9	8			160	11	28	28	28	28	28	28	/	/	/	/	/
	90 B5	130	•	•	165	4.5	11	8			200	12	/	/	/	/	/	/	24	/	24	24	24
	90 B14	95	•	•	115	4	9	8		4	140	12	/	/	/	/	/	/	24	/	24	24	24
110	100/112 B5	180	•	•	215	5	14	8			250	14	28	28	28	28	28	28	28	28	28	28	28
	100/112 B14	110	•	•	130	4.5	9	8		4	160	12	28	28	28	28	28	28	28	28	28	28	28
	132 B5	230	•	•	265	5	14	4			300	14	38	38	38	38	38	38	/	/	/	/	/
	132 B14	130	•	•	165	4.5	11	4			200	12	38	38	38	38	38	38	/	/	/	/	/
	90 B5	130	•	•	165	4.5	11	8			200	12	/	/	/	/	/	/	/	/	24	24	24
130	90 B14	95	•	•	115	4	9	8		4	140	12	/	/	/	/	/	/	/	/	24	24	24
	100/112 B5	180	•	•	215	5	14	8			250	14	28	28	28	28	28	28	28	28	28	28	28
	100/112 B14	110	•	•	130	4.5	9	8		4	160	12	28	28	28	28	28	28	28	28	28	28	28
	132 B5	230	•	•	265	5	14	4			300	14	38	38	38	38	38	38	38	/	/	/	/
	132 B14	130	•	•	165	4.5	11	4			200	12	38	38	38	38	38	38	38	/	/	/	/