

## Редуктор, Мотор-редуктор RCV 452, 453 VARMEC

CV RCV	i	n <sub>1</sub> = 2800 min <sup>-1</sup>			n <sub>1</sub> = 1400 min <sup>-1</sup>			n <sub>1</sub> = 900 min <sup>-1</sup>					
		n <sub>2</sub> min <sup>-1</sup>	Mn <sub>2</sub> Nm	P <sub>1</sub> kW	n <sub>2</sub> min <sup>-1</sup>	Mn <sub>2</sub> Nm	P <sub>1</sub> kW	n <sub>2</sub> min <sup>-1</sup>	Mn <sub>2</sub> Nm	P <sub>1</sub> kW	IEC B5	IEC B14	NEMA
452	4.42	633	479	33	317	574	19.8	204	574	12.7	80-90-100-112-132	132	140-180-210
	4.89	573	478	30	286	572	17.9	184	572	11.5	80-90-100-112-132	132	140-180-210
	5.43	516	479	27	258	573	16.1	166	573	10.4	80-90-100-112-132	132	140-180-210
	6.07	461	477	24	231	571	14.4	148	571	9.2	80-90-100-112-132	132	140-180-210
	8.14	344	519	19.5	172	621	11.7	111	622	7.5	80-90-100-112-132	132	140-180-210
	9.00	311	534	18.1	156	640	10.9	100	640	7.0	80-90-100-112-132	132	140-180-210
	10.00	280	550	16.8	140	659	10.1	90	659	6.5	80-90-100-112-132	132	140-180-210
	11.18	250	552	15.1	125	662	9.0	81	662	5.8	80-90-100-112-132	132	140-180-210
	12.89	217	529	12.5	109	634	7.5	70	633	4.8	80-90-100-112-132	132	140-180-210
	14.25	196	545	11.7	98	652	7.0	63	653	4.5	80-90-100-112-132	132	140-180-210
	15.83	177	560	10.8	88	671	6.5	57	671	4.2	80-90-100-112-132	132	140-180-210
	17.70	158	563	9.7	79	674	5.8	51	673	3.7	80-90-100-112-132	132	140-180-210
	19.99	140	539	8.2	70	646	4.9	45.0	645	3.2	80-90-100-112-132	132	140-180-210
	22.09	127	557	7.7	63	667	4.6	40.7	666	3.0	80-90-100-112-132	132	140-180-210
	24.55	114	570	7.1	57	683	4.2	36.7	683	2.7	80-90-100-112-132	132	140-180-210
	27.45	102	571	6.4	51	683	3.8	32.8	684	2.4	80-90-100-112-132	132	140-180-210
	30.93	91	587	5.8	45.3	702	3.5	29.1	702	2.2	80-90-100-112-132	132	140-180-210
	31.20	90	507	5.0	44.9	607	3.0	28.8	607	1.9	80-90-100-112	—	140-180-210
34.67	81	563	5.0	40.4	674	3.0	26.0	675	1.9	80-90-100-112	—	140-180-210	
38.76	72	461	3.6	36.1	553	2.2	23.2	551	1.4	80-90-100-112	—	140-180-210	
43.68	64	520	3.6	32.1	623	2.2	20.6	621	1.4	80-90-100-112	—	140-180-210	
453	31.10	90	544	5.5	45.0	653	3.3	28.9	651	2.1	71-80-90-100-112	100-112	140-180
	34.40	81	559	5.1	40.7	669	3.1	26.2	669	2.0	71-80-90-100-112	100-112	140-180
	38.20	73	575	4.7	36.7	688	2.8	23.6	687	1.8	71-80-90-100-112	100-112	140-180
	42.70	66	575	4.2	32.8	688	2.5	21.1	689	1.6	71-80-90-100-112	100-112	140-180
	45.70	61	547	3.8	30.6	656	2.3	19.7	656	1.5	71-80-90-100-112	100-112	140-180
	50.50	55	562	3.5	27.7	674	2.1	17.8	675	1.4	71-80-90-100-112	100-112	140-180
	56.10	49.9	576	3.2	25.0	692	1.9	16.0	690	1.2	71-80-90-100-112	100-112	140-180
	62.70	44.7	577	2.9	22.3	694	1.7	14.4	691	1.1	71-80-90-100-112	100-112	140-180
	76.80	36.5	551	2.3	18.2	660	1.4	11.7	657	0.87	71-80-90-100-112	100-112	140-180
	84.90	33.0	566	2.1	16.5	676	1.3	10.6	676	0.81	71-80-90-100-112	100-112	140-180
	94.30	29.7	581	1.9	14.8	698	1.2	9.5	696	0.75	71-80-90-100-112	100-112	140-180
	105.50	26.5	580	1.7	13.3	693	1.0	8.5	695	0.67	71-80-90-100-112	100-112	140-180
	123.81	22.6	610	1.5	11.3	730	0.90	7.3	730	0.58	71-80-90-100-112	100-112	140-180
	147.20	19.0	554	1.2	9.5	661	0.71	6.1	666	0.46	71-80-90-100-112	100-112	140-180
	162.70	17.2	571	1.1	8.6	679	0.66	5.5	681	0.42	71-80-90-100-112	100-112	140-180
	180.70	15.5	594	1.0	7.7	708	0.62	5.0	711	0.40	71-80-90-100-112	100-112	140-180
	202.10	13.9	601	0.94	6.9	716	0.56	4.5	716	0.36	71-80-90-100-112	100-112	140-180
	227.70	12.3	626	0.87	6.1	749	0.52	4.0	750	0.33	71-80-90-100-112	100-112	140-180

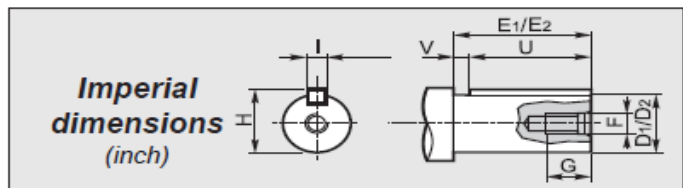
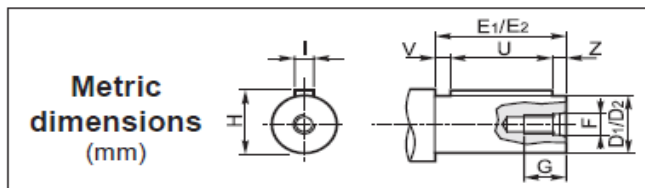

① **Albero entrata / Input shaft / Antriebswelle**  
**Arbre d'entrée / Eje de entrada / Eixo de entrada**

CV RCV	D <sub>1</sub> h6	E <sub>1</sub>	F	G	H	I	U	V	Z
452	28	60	M10	20	31	8	50	5	5
453	24	50	M8	18	27	8	40	5	5

① **Albero entrata / Input shaft / Antriebswelle**  
**Arbre d'entrée / Eje de entrada / Eixo de entrada**

CV RCV	D <sub>1</sub>	E <sub>1</sub>	F	G	H	I	U	V
452	1.125	2.362	5/16-18	0.709	1.236	0.250	1.750	0.612
453	1.000	1.969	5/16-18	0.709	1.109	0.250	1.500	0.469

② **Albero uscita / Output shaft / Abtriebswelle**  
**Arbre de sortie / Eje de salida / Eixo de saída**

CV RCV	D <sub>2</sub> h6	E <sub>2</sub>	F	G	H	I	U	V	Z
452 453	38	80	M10	22	41	10	70	5	5
	40	90	M12	33	43	12	80	5	5
	42	90	M12	33	45	12	80	5	5
	45	90	M12	33	48.5	14	70	10	10
	48	90	M12	33	51.5	14	70	10	10
50	100	M16	45	53.5	14	90	5	5	

② **Albero uscita / Output shaft / Abtriebswelle**  
**Arbre de sortie / Eje de salida / Eixo de saída**

CV RCV	D <sub>2</sub>	E <sub>2</sub>	F	G	H	I	U	V
452 453	1.750	3.543	1/2-13	1.299	1.917	0.375	3.000	0.543

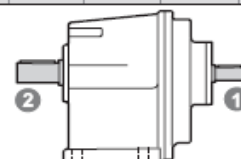

## Редуктор, Motor-редуктор RCV 452, 453 VARMEC

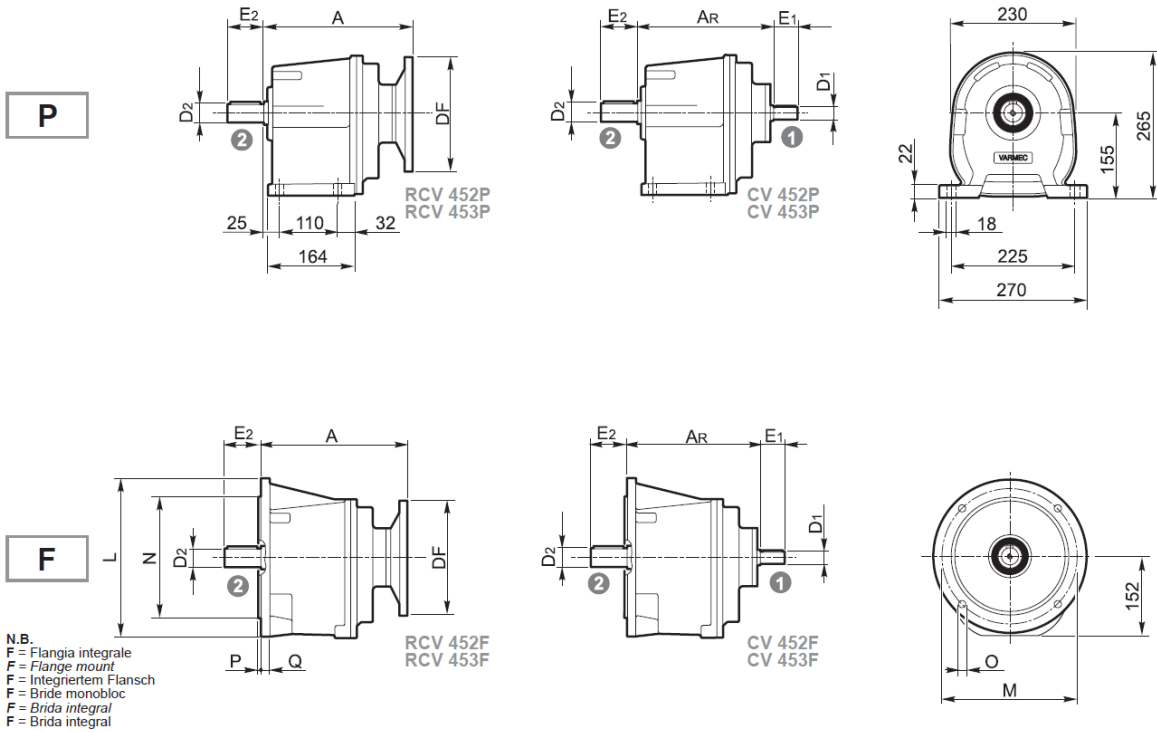

RCV CV	RCV							CV
	IEC	DF		A	NEMA	DF	A	
		(B5)	(B14)					AR
452	80	200		250	140	165.1	266	245
	90	200			180	228.6	272	
	100	250			210	228.6	272	
	112	250						
	132	300	200	265				
453	71	160		260	140	165.1	270	255
	80	200			180	228.6	276	
	90	200						
	100	250	160					
	112	250	160					

	L	M	N h8	O	P	Q
F300	300	265	230	14	5	17