

MBH 140

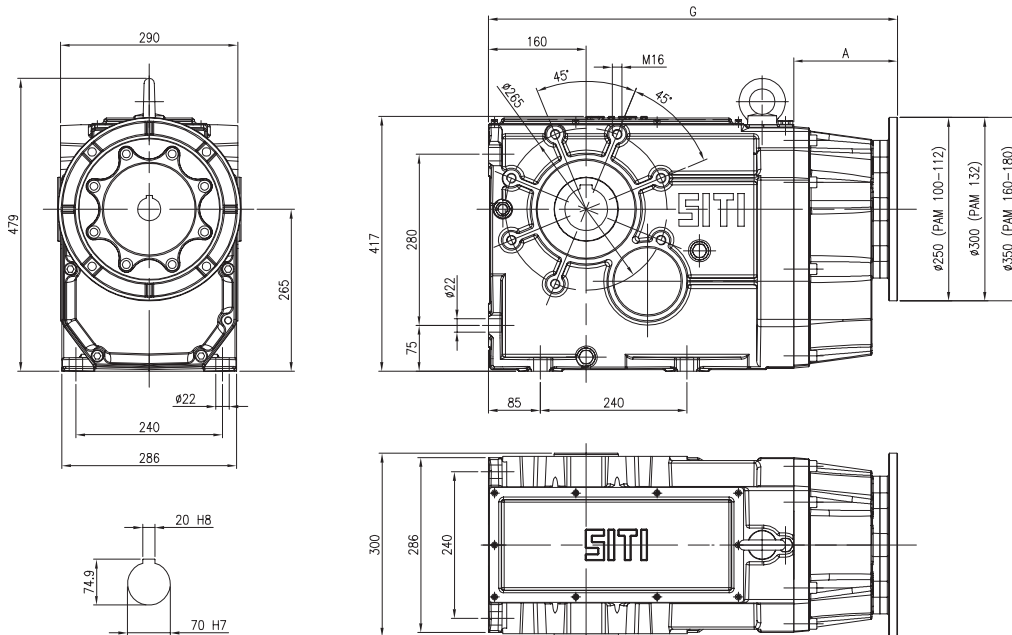

MBHGC 140

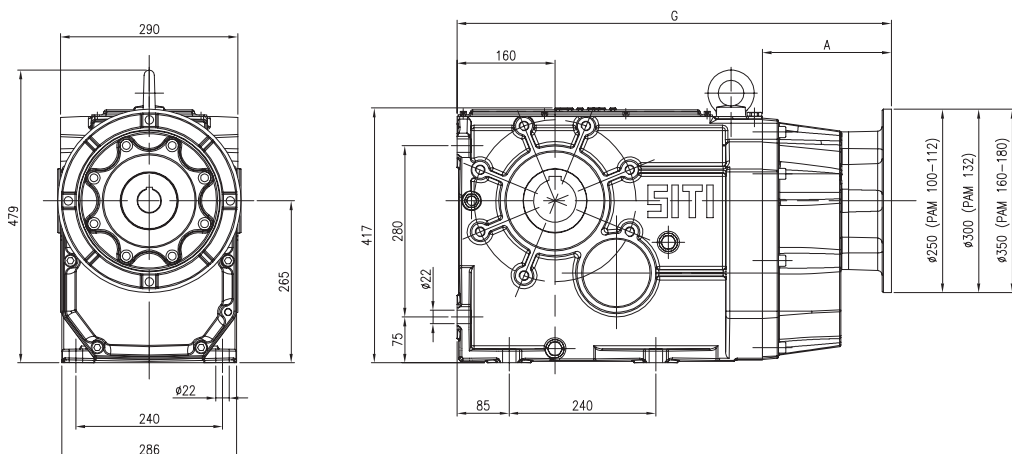

| | A | B | C | D | E | F | G |
|------------------------|-----|-----|-----|-----|-----|-----|-------|
| BH 140 | | | | | | | 728,5 |
| MBH140 PAM 100 | 170 | | | | | | 669,5 |
| MBH140 PAM 112 | 170 | | | | | | 669,5 |
| MBH140 PAM 132 | 170 | | | | | | 669,5 |
| MBHGC140 GR.100 | 211 | | | | | | 710,5 |
| MBHGC140 GR.112 | 211 | | | | | | 710,5 |
| MBHGC140 GR.132 | 211 | | | | | | 710,5 |
| MBHGC140 GR.160 | 270 | | | | | | 769,5 |
| MBHGC140 GR.180 | 270 | | | | | | 769,5 |
| MBHC140 GR.100 | | 316 | 138 | 192 | 403 | 85 | 815,5 |
| MBHC140 GR.112 | | 340 | 150 | 216 | 415 | 100 | 839,5 |
| MBHC140 GR.132S | | 391 | 178 | 257 | 443 | 100 | 890,5 |
| MBHC140 GR.132M | | 429 | 178 | 257 | 443 | 100 | 928,5 |

BH 140

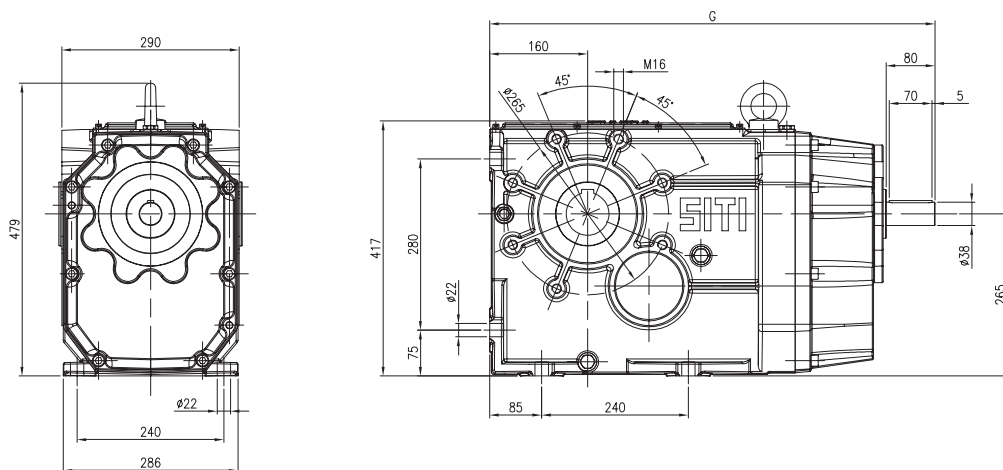

MBHC 140

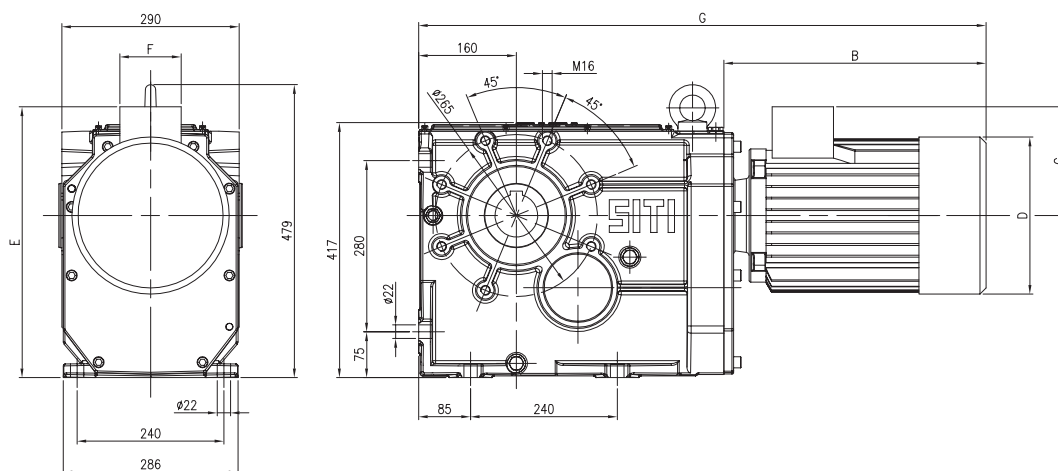

PAM DISPONIBILI

PAM VERSIONS AVAILABLE

VERFÜGBARE "PAM" AUSFÜHRUNGEN

| i | MBH | | | MBHGC | | | | | MBHC | | | |
|--------|-----|-----|-----|-------|-----|-----|-----|-----|------|-----|------|------|
| | 100 | 112 | 132 | 100 | 112 | 132 | 160 | 180 | 100 | 112 | 132S | 132M |
| 7,64 | | | | | | | | | | | | |
| 9,35 | | | | | | | | | | | | |
| 10,93 | | | | | | | | | | | | |
| 12,09 | | | | | | | | | | | | |
| 14,79 | | | | | | | | | | | | |
| 17,28 | | | | | | | | | | | | |
| 19,24 | | | | | | | | | | | | |
| 20,96 | | | | | | | | | | | | |
| 22,77 | | | | | | | | | | | | |
| 25,64 | | | | | | | | | | | | |
| 31,01 | | | | | | | | | | | | |
| 33,36 | | | | | | | | | | | | |
| 35,58 | | | | | | | | | | | | |
| 41,30 | | | | | | | | | | | | |
| 48,65 | | | | | | | | | | | | |
| 64,70 | | | | | | | | | | | | |
| 81,33 | | | | | | | | | | | | |
| 101,33 | | | | | | | | | | | | |
| 125,12 | | | | | | | | | | | | |
| 140,98 | | | | | | | | | | | | |
| 162,12 | | | | | | | | | | | | |
| 182,10 | | | | | | | | | | | | |

Il motore grandezza 200 può essere montato solo in tipologia B3, con giunto senza campana.

Motor size 200 can be mounted only in B3 type, with coupling and without bell-housing.

Der Motor in Baugroesse 200 kann nur in Bauform B3 eingebaut werden; mit Kupplung aber ohne Glocke.